

STATE OF CALIFORNIA
DEPARTMENT OF GENERAL SERVICES - PROCUREMENT DIVISION



Invitation For Bid

Responses must be delivered to the Procurement Division before 2:00 PM on the Due Date

DUE DATE 1/15/2009		SOLICITATION NO. 57178				REV. 11/18/2008	DELIVERY DATE 545 Days ARO	PAGE 1
SUPPLIER NAME AND ADDRESS		PURCHASE EST. NO. 67336	REV.	AGENCY BILLING CODE 60145	AGENCY PURCHASE EST. NO. 04-2156JW			
SUPPLIER CONTACT: PHONE: SUPPLIER NUMBER:		F.O.B. DESTINATION UNLESS BIDDER STATES OTHERWISE			ARE YOU CLAIMING PREFERENCE AS A CALIFORNIA CERTIFIED SMALL BUSINESS? YES <input type="checkbox"/> NO <input type="checkbox"/>		IF YES, MANUFACTURER? YES <input type="checkbox"/> NO <input type="checkbox"/>	
NAME (PRINT)		% CASH DISCOUNT FOR PAYMENT WITHIN ___ DAYS.		SHIP TO: CALTRANS 320 22ND STREET OAKLAND, CA 94612		ARE YOU A NON-SMALL BUSINESS CLAIMING AT LEAST 25% SMALL BUSINESS SUBCONTRACTOR PREFERENCE? YES <input type="checkbox"/> NO <input type="checkbox"/>		
TITLE		FOR FURTHER BUYER INFORMATION,		PHONE		SECTION 14835 ET SEQ. OF THE CALIFORNIA GOVERNMENT CODE REQUIRES THAT A 5% PREFERENCE BE GIVEN TO BIDDERS WHO QUALIFY AS A SMALL BUSINESS OR BIDDERS WHO QUALIFY AS A NON-SMALL BUSINESS CLAIMING AT LEAST 25% CALIFORNIA CERTIFIED SMALL BUSINESS PARTICIPATION. FOR REQUIREMENTS SEE TITLE 2, CALIFORNIA CODE OF REGULATIONS, SECTION 1896, ET SEQ. THE REQUIREMENTS FOR NONPROFIT VETERAN SERVICE AGENCIES QUALIFYING AS A SMALL BUSINESS ARE CONTAINED IN SECTION 999.50 ET SEQ. OF THE MILITARY AND VETERANS CODE.		
SIGNATURE _____ DATE _____		CONTACT KATHLEEN SANBORN		916-375-4403				
TELEPHONE NUMBER _____ FAX NUMBER _____		Return To: DGS/PROCUREMENT DIVISION 707 3RD ST. 2ND FL(95605) P.O. BOX 989054 W SACRAMENTO, CA 95798						
FEDERAL EMPLOYER IDENTIFICATION NUMBER								

Bidder offers and agrees if this response is accepted within 45 calendar days from the date of opening to furnish all of the items upon which prices are quoted, at the prices set opposite each item, delivered at the designated point(s) by the method of delivery and within the times specified above and subject to the attached General Provisions. **DECLARATIONS UNDER PENALTY OF PERJURY:** By signing above, with inclusion of the date of signature, the above signed bidder **DECLARES UNDER PENALTY OF PERJURY** under the laws of the State of California as follows: (1) (STATEMENT OF COMPLIANCE). The above signed has complied with the non-discrimination program requirements of Government Code 12990 and Title 2, California Administrative Code Section 8103, and such declaration is true and correct. (2) The National Labor Relations Board declaration set forth in Paragraph 43 of the General Provisions is true and correct. (3) If a claim is made for the small business preference, the information set forth within is true and correct.

ITEM NO.	QUANTITY	UNIT	COMMODITY CODE	DESCRIPTION	UNIT PRICE	EXTENSION
ADDENDUM #2 DECEMBER 19, 2008						
This addendum is for solicitation #57178 for a ferry boat. The following changes have been made:						
1. Clarification: The bid due date is January 15, 2009 at 2 PM.						
2. Add the attached Contract Guidance Plan Number 579-01-504 of Void Ventilation.						
3. A site visit is scheduled for Thursday, January 8, 2009, at 10 AM, for the agency and interested/prospective bidders to view the current ferry in operation. No bidders will be allowed into the site visit after 10:10 AM.						
Location of the site visit: Department of Transportation (Cal-Trans) Rio Vista Maintenance Station 440 Highway 12 Rio Vista, CA 94571						
If you are planning on attending this site visit, please contact Kathleen Sanborn via e-mail at kathleen.sanborn(at)dgs.ca.gov and confirm your company's attendance with the following information: Company Name Name(s) of Person(s) attending						
A guided tour will be given below the deck of the ferry. Works clothes						

IMPORTANT: Read attached General Provisions carefully before bidding.

STATE OF CALIFORNIA
DEPARTMENT OF GENERAL SERVICES
PROCUREMENT DIVISION

Invitation For Bid Continuation

SUPPLIER NAME	SOLICITATION NO.	REV.	PAGE
	57178		2

ITEM NO.	QUANTITY	UNIT	COMMODITY CODE	DESCRIPTION	UNIT PRICE	EXTENSION
<p>and shoes are advised. A hard hat and vest will be provided to each attendee upon arrival at the site.</p> <p>All other terms and conditions remain the same.</p>						

DO NOT SCALE. IF IN DOUBT, ASK

DIST	COUNTY	ROUTE	KILOMETER POST TOTAL PROJECT	SHEET No	TOTAL SHEETS
04	SOL	84	4.0	2	3

D. A. RICCIUTI
REGISTERED MARINE ENGINEER



08/25/2008
PLANS APPROVAL DATE

The State of California or its officers or agents shall not be responsible for the accuracy or completeness of electronic copies of this plan sheet.

MARK THOMAS & CO., INC. SEAWORTHY SYSTEMS, INC.
1960 ZANKER ROAD 22 MAIN STREET
SAN JOSE, CA 95112 ESSEX, CT 06426

CALTRANS
111 GRAND AVENUE
9TH FLOOR, MS7B
OAKLAND, CA 94623-0660

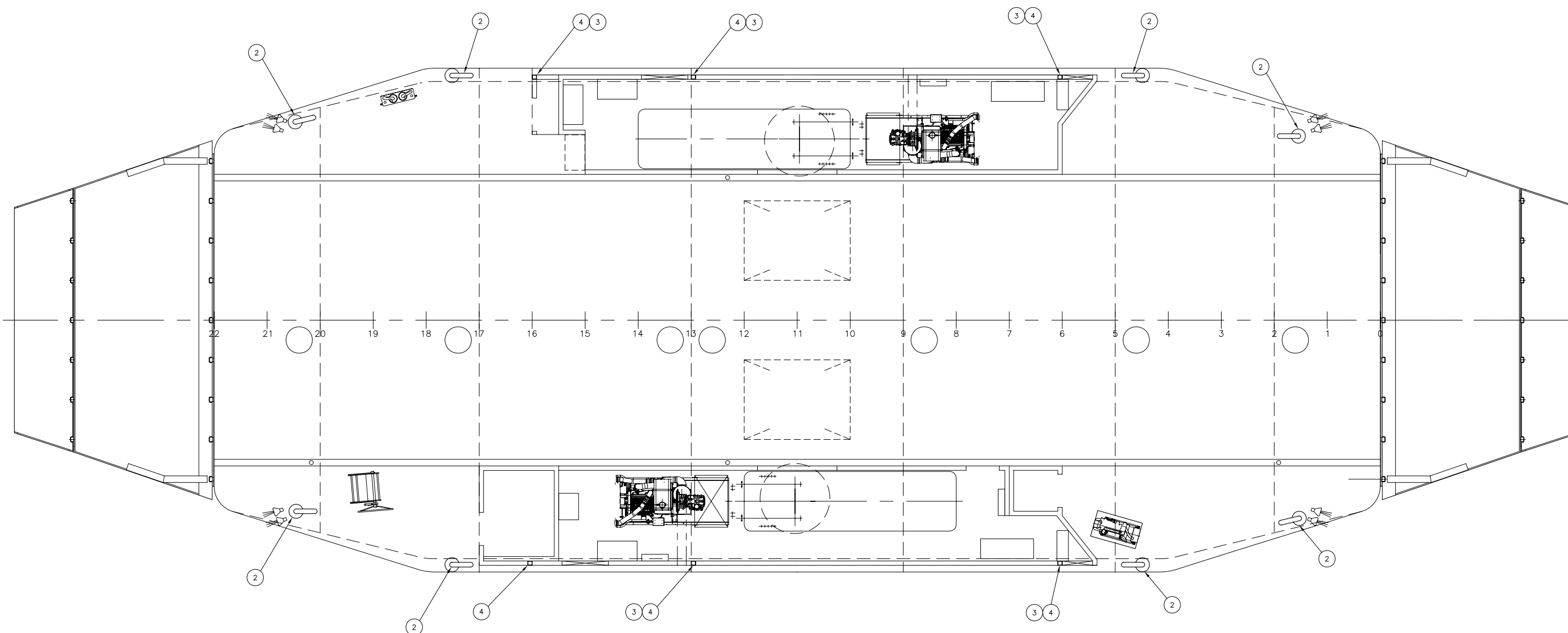

LOCATION OF VOID VENTS
N.T.S.

ROBERT CAMARGO
DESIGN OVERSIGHT
3-14-06
SIGN OFF DATE

DESIGN	BY DR	CHECKED JAH
DETAILS	BY ---	CHECKED ---
QUANTITIES	BY ---	CHECKED ---

PREPARED FOR THE
STATE OF CALIFORNIA
DEPARTMENT OF TRANSPORTATION

JIM SIMS
PROJECT ENGINEER

BRIDGE NO.	23-0034
KILOMETER POST	4.0

CACHE SLOUGH FERRY REPLACEMENT
VOID VENTILATION
579-01-504

DESIGN DETAIL SHEET (INCHES) (---/---/---)

ORIGINAL SCALE IN INCHES
1/4" = 1'-0"

CU 04-609
EA 04-443601

DISREGARD PRINTS BEARING
EARLIER REVISION DATES

REVISION DATES (PRELIMINARY STAGE ONLY)		
2/24/06	3/8/06	11/22/06

SHEET	OF
2	3

FILE => \$REQUEST

TIME PLOTTED => \$TIME

DATE PLOTTED => \$DATE

USERNAME => \$USER

DO NOT SCALE. IF IN DOUBT, ASK

DIST	COUNTY	ROUTE	KILOMETER POST TOTAL PROJECT	SHEET No	TOTAL SHEETS
04	SOL	84	4.0	3	3

D. A. RICCIUTI
REGISTERED MARINE ENGINEER

08/25/2008
PLANS APPROVAL DATE

The State of California or its officers or agents shall not be responsible for the accuracy or completeness of electronic copies of this plan sheet.

MARK THOMAS & CO., INC. SEAWORTHY SYSTEMS, INC.
1960 ZANKER ROAD 22 MAIN STREET
SAN JOSE, CA 95112 ESSEX, CT 06426

CALTRANS
111 GRAND AVENUE
9TH FLOOR, MS7B
OAKLAND, CA 94623-0660

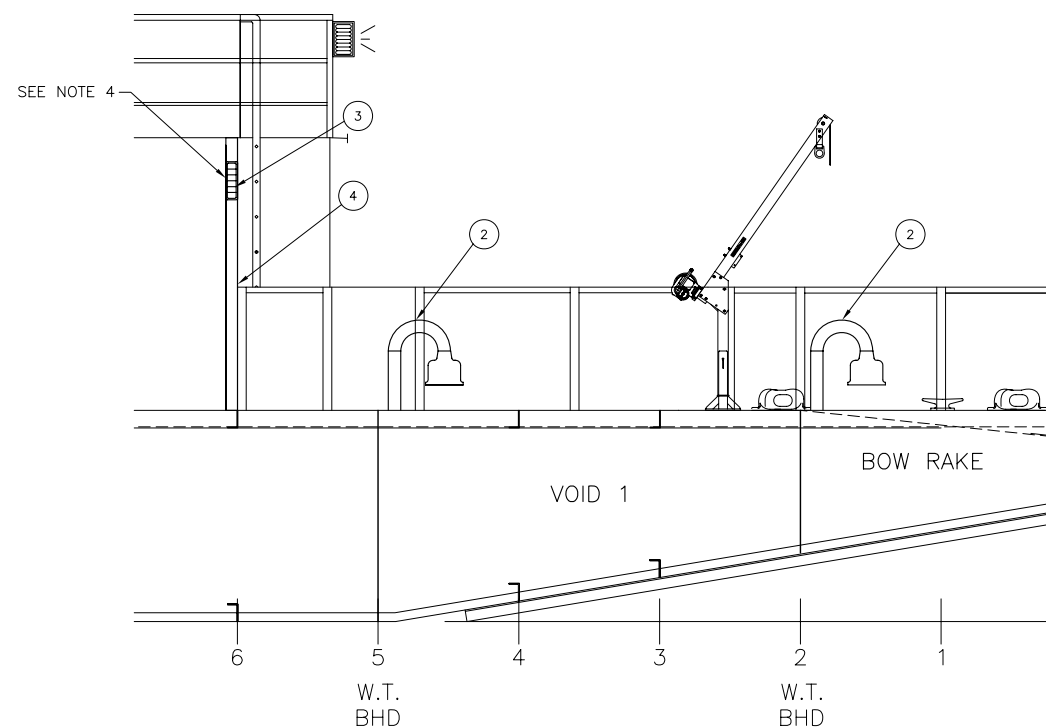

TYPICAL PROFILE OF VOID VENTS
N.T.S.

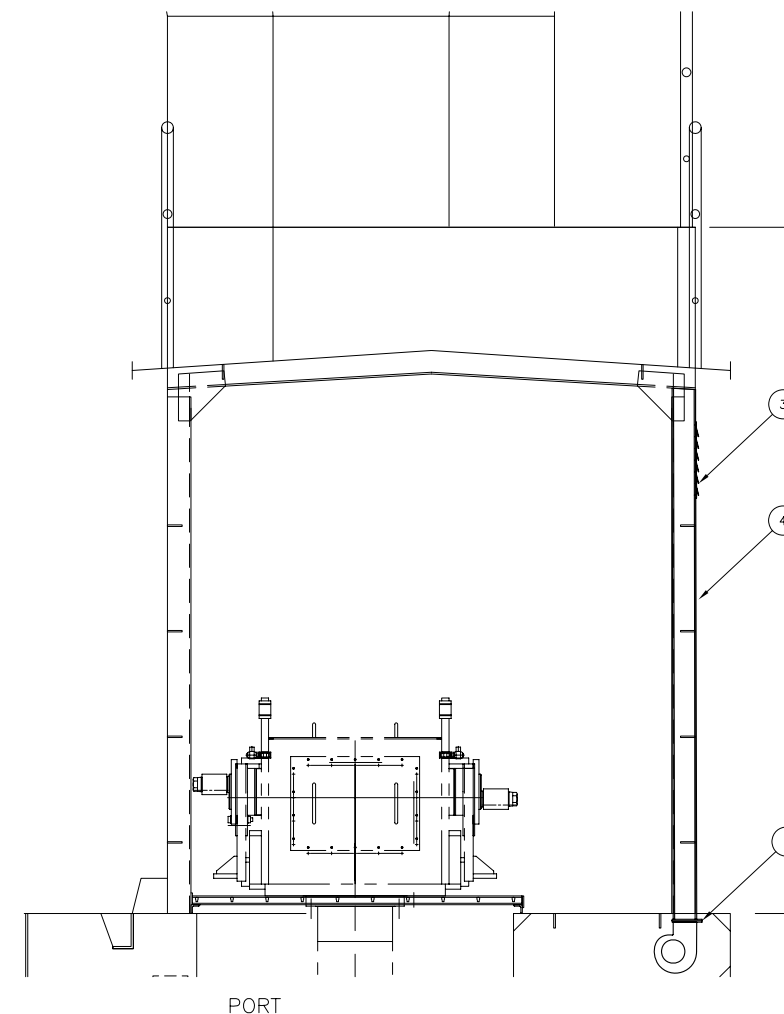
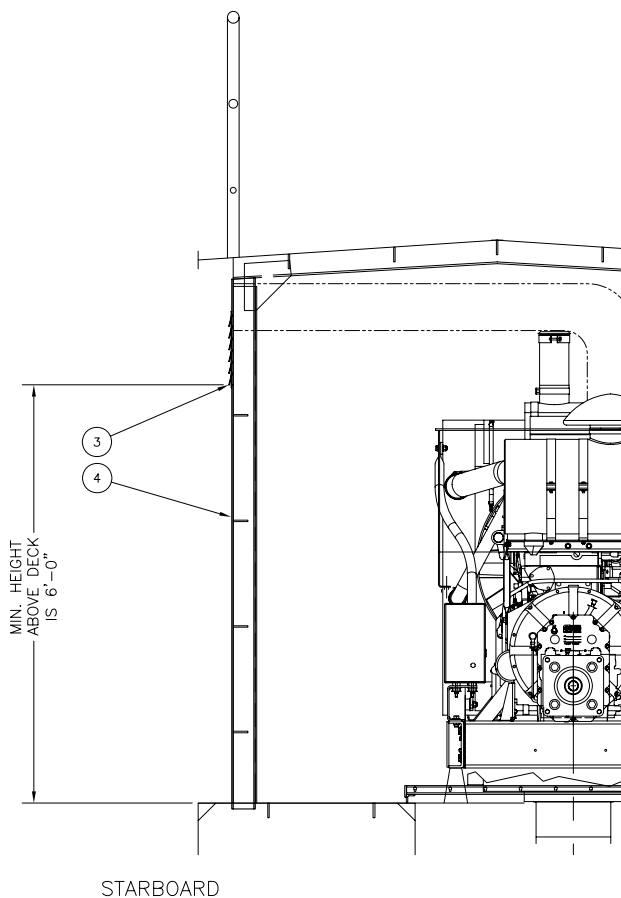

TYPICAL CROSS SECTION OF VOID VENTS
N.T.S.

ROBERT CAMARGO
DESIGN OVERSIGHT
3-14-06
SIGN OFF DATE

DESIGN	BY DR	CHECKED JAH
DETAILS	BY ---	CHECKED ---
QUANTITIES	BY ---	CHECKED ---

PREPARED FOR THE
STATE OF CALIFORNIA
DEPARTMENT OF TRANSPORTATION

JIM SIMS
PROJECT ENGINEER

BRIDGE NO.	23-0034
KILOMETER POST	4.0

CACHE SLOUGH FERRY REPLACEMENT
VOID VENTILATION
579-01-504

DESIGN DETAIL SHEET (INCHES) (---/---/---)

ORIGINAL SCALE IN INCHES
1/4" = 1'-0"

CU 04-609
EA 04-443601

DISREGARD PRINTS BEARING
EARLIER REVISION DATES

REVISION DATES (PRELIMINARY STAGE ONLY)		
2/24/06	3/8/06	11/22/06

SHEET	OF
3	3

FILE => \$REQUEST

DATE PLOTTED => \$DATE
TIME PLOTTED => \$TIME
USERNAME => \$USER